



Model GFPV Relay

GROUND FAULT CURRENT DETECTION with Voltage and Fuse Monitoring

The GFPV system is designed for electrical equipment protection, not for personnel protection.

Application: Ground Fault Relay, with optional Voltage and Fuse Monitors.

Trip Currents: 5-60, 30-360, and 100-1200A

Ground Fault Section: These Class 1 Ground Fault relays and sensors are used together to provide a system for detecting ground fault current in a grounded AC power system.

Note: The Ground Fault Sensors (Model GFL) are sold separately. Please see our GFL Sensor selection to determine proper size and shape for the application. ([Sensor Data Sheet](#))

For systems not requiring voltage or fuse monitoring, please see our Model [GFP Ground Fault Relay](#).

Fuse Monitor Section (Optional): The Fuse Monitoring section of the GFPV is used to send a trip signal in case of an open fuse in the service being monitored.

Voltage Monitoring Section (Optional): The voltage monitoring section monitors all three phases for phase loss, phase reversal, over voltage, under voltage, and phase unbalance.

Input Power Options: Three Phase 208, 240, 480, 575, or 600Vac

Nominal Input Voltage: Input power comes from the three phases being monitored.

Frequency: 50/60 Hz

Ground Fault: Trip currents ranges available: 5-60, 30-360, and 100-1200A.

Input Withstand: 200,000 Amperes RMS for 3 cycles, 50/60 Hz.

Ambient Temperature Range: -30 Deg C. to 60 Deg C.

- Meets NEC service entrance equipment standards.
- Contact ratings (both Trip and Alarm) "Form C", Dry Type, 250Vac, Inrush=400A, and Continuous = 16A
- Operates with molded case power circuit breakers, bolted pressure switches, or fusible disconnect switches.
- Optional Remote Indicator with data capture capability
- Ground Fault Section:
 - Positive visual trip indicator.
 - Real time fault current level indicator.
 - Two (2) Styles: "Standard" (without interlock) and "Zone Interlocking"
 - Discrete current and time delay threshold
 - Integral test panel with "Push to Test" and "Shunt Trip Bypass" pushbuttons for proper testing of device with the ability to trip or not to trip the protective device.
 - Adjustable time delay with four time delay characteristics options (See sheet 4 & 5)
- Voltage Monitor Section:
 - Separate time delay adjustments for Voltage Monitor Section (0 - 30 sec)
 - Adjustable time delay to reset for Voltage Monitor (1 – 300 sec.)
 - Phase reversal
 - Under voltage (80% Normal voltage)
 - Over voltage (115% Normal voltage)
 - Phase loss
 - Adjustable Unbalance set-point (2% to 12%)
- Fuse Monitor Section
 - Indicates fuse status and initiates a trip on an open fuse condition

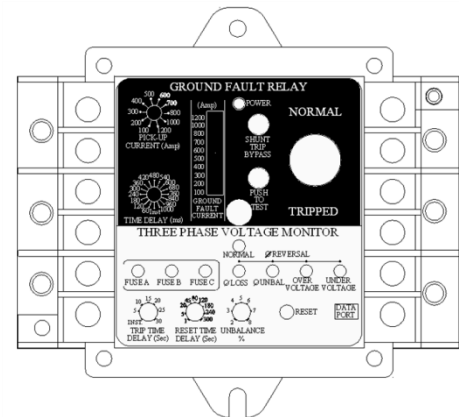



Electromagnetic Industries LLP

www.electromagnetic.biz

GFPV with Voltage Monitor:

The typical configuration of the GFPV with Voltage Monitoring and Fuse Relay will protect a three phase power system from ground fault, phase reversal, phase unbalance, phase loss, over voltage, under voltage, and open fuse conditions.

The GFPV is designed to be used in a system where changing the state of the relay contacts may interrupt the buss power being monitored and used to energize the relay.

When operating in a normal condition, the “Normal”, and all three “Fuse” indication LEDs will be illuminated green. The “Alarm” and “TRIP” relay contacts will be de-energized.

Ground Fault: The GFPV relay will indicate the level of the ground fault on the bar graph. If the ground fault exceeds the set level the “Alarm” contacts will change state. If the condition continues for the allotted time delay, the contact switch on the front of the GFPV will move to the “Tripped” position and change state of the trip contacts. If any of the three phases are still available, the GFPV will continue to indicate the level the ground fault current was at the time of the trip.

Note: To reset the Ground Fault section, the contact switch on the front of the GFPV must be placed back to the “Normal” position.

Open Fuse: The GFPV relay will instantaneously change state of both the “Alarm” and “Trip” relays and the “Normal” LED will extinguish.

Phase Reversal: The GFPV relay will instantaneously change state of both the “Alarm” and “Trip” relays and the “Normal” LED will extinguish. If power is still available on any of the three phases, the red LEDs will flash from left to right.

Phase Unbalance, Phase Loss, Under Voltage, or Over Voltage: The corresponding LED will illuminate. The “Alarm” contacts will change state and the trip time delay will begin. If the condition has not cleared before the time delay expires, the “Trip” contacts will change state.

For any Voltage Monitor fault detection, if the condition clears before reaching the time delay setting, the GFPV will clear the fault indication, reset the “Alarm” contacts, and reset all time delays.

Indications:

- On the Fuse and Voltage Monitor section of the GFPV, if power is still available on any of the three phases after the trip, the LEDs will indicate the condition at power down/trip.
- If the external 12V power option is selected and applied, the LEDs will flash indicating the condition at power down/trip.
- If power is not available after the trip, the fault can be indicated by depressing the “Reset / Trip Indication” pushbutton. (If done w/in 3 hours of the trip. (If the unit has been powered up for a minimum of 4 hours prior to the trip.)

Resetting Unit

- There is an adjustable “Time to Reset” on the Voltage Monitor section that will allow for 1 – 300 sec. between the condition clearing and the relay resetting to the “Normal” condition. This time delay will only be initiated if the GFPV has not lost power between “Trip” and the condition clearing. During this time, the LED indicating the reason for the trip will extinguish and the green “Normal” LED will flash. To over-ride this time delay, press the “Reset / Trip Indication” push button.
- The GFPV will automatically reset any Voltage Monitor or Open Fuse Alarm and Trip at Power Up.



Electromagnetic Industries LLP

www.electromagnetic.biz

GFPV Selection Guide:

Use the following selections to determine part number for GFPV configuration.

Options	1	2	3	4	5	6	7	8	9	10	11	12
Model	Voltage	Trip Current (See Pages 3&4)	Ground Fault*	Fuse Indication*	Over Voltage*	Under Voltage*	Unbalance*	Phase Loss*	Time Delay	Remote Monitor**	Interlock Option	Auxiliary Power Adaptor***
GFPV1	1 = 208	1 = 5A - 60A							1 = Standard	1 = Yes	1 = Yes	1 = Yes
	2 = 240	2 = 30A – 360A							2 = Linear Inverse	2 = No	2 = No	2 = No
	3 = 480	3 = 100A – 1200A							3 = Logarithmic Inverse			
	4 = 575								4 = 2 sec. Inverse			
	5 = 600											

*** Select Required Action:**
 0 = No action required
 1 = Alarm Contacts Only
 2 = Alarm & Trip Contacts
 3 = Trip Contacts Only

**** Selection is for Remote Monitor interface. (Remote Monitor sold separately)**

***** Selection is for Auxiliary Power Adaptor Connection. (Adaptor sold separately)**

Example: Part number GFPV1332-22222-1222 configuration would be GFPV1, 480Vac, 100-1200A ground fault w/alarm & trip contacts, fuse, over voltage, under voltage, unbalance and phase loss, all w/alarm & trip contacts, the standard 1 Sec time delay (for ground fault), no remote monitor, no zone interlock, no auxiliary power connection.

NOTE: The GFPV Ground Fault Relay needs to be connected to the GFL series sensor to operate. Please see the GFL sensors to determine proper size and part number for the specific application. ([Sensor Data Sheet](#))



TYPICAL RESPONSE CURVES (Model GFPV)

(OPTION 1)

With the Option 1 Time Delay Curve, the ground fault must be present for the full length of the time delay. The ground fault amperage level does not affect the time delay. (i.e. The time delay will always be as set regardless of the amperage of the ground fault.)

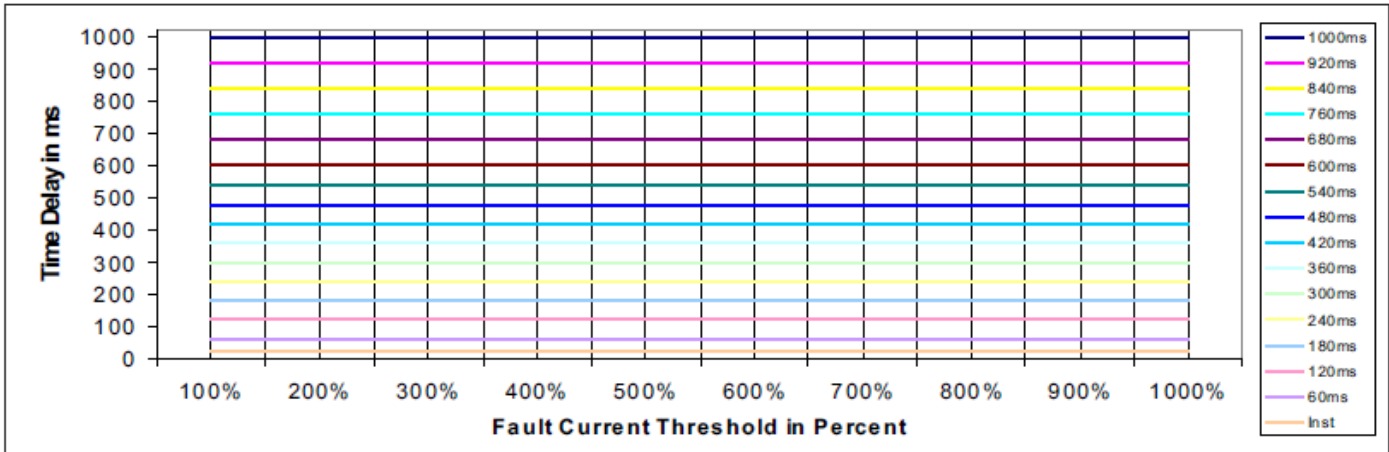

Note: With Options 2 – 4 of the time delay curves, the units have an inverse time function. (i.e. The time delay is determined by the time delay setting and the amperage level of the ground fault.)

(OPTION 2)

With the Option 2 Time Delay Curve, the ground fault level may affect the time delay. The higher the ground fault level above the set-point, the faster the GFPV will trip. For every 100% above the threshold set-point, the time delay is reduced to ½.

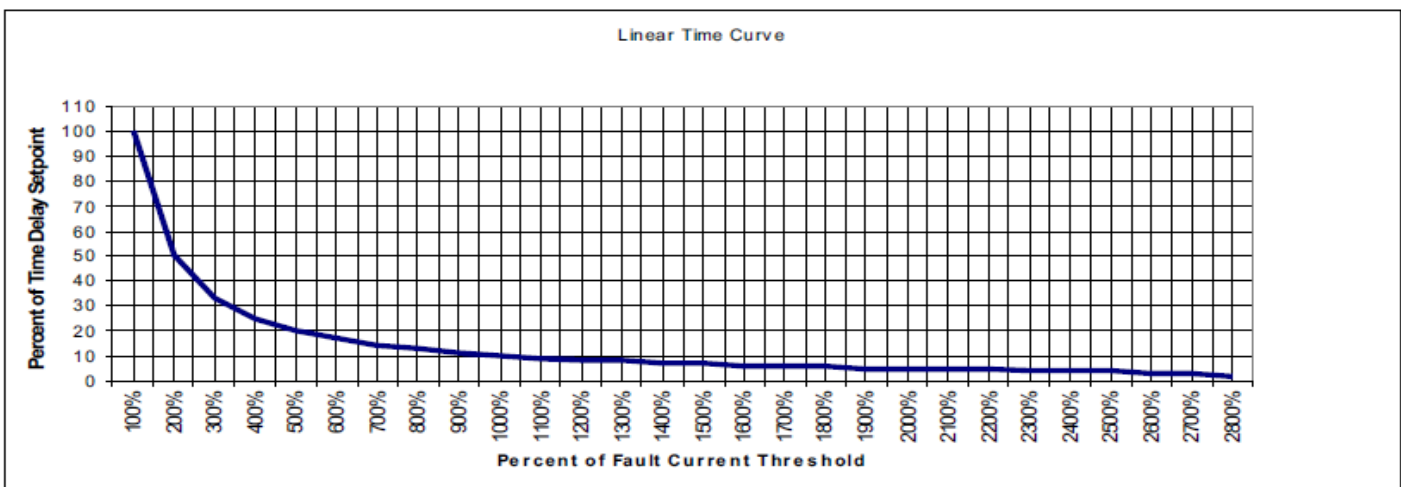



(OPTION 3)

With the Option 3 Time Delay Curve, the ground fault level may affect the length of the time delay. The higher the ground fault level above the set-point, the faster the GFPV will trip. For every 100% above the threshold set-point, the time delay is reduced to 1/4.

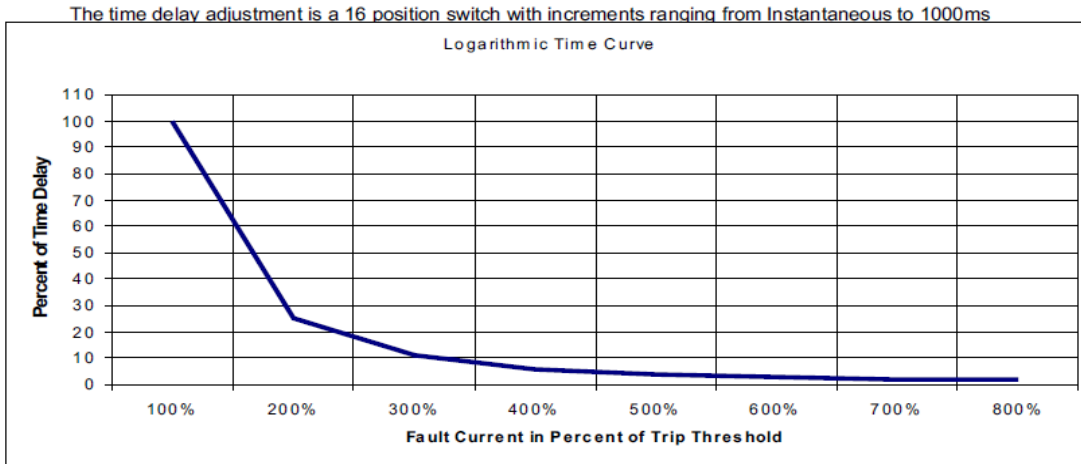

(OPTION 4)

The Option 4 Time Delay Curve allows for up to 2 sec. Time Delay while still meeting UL and NEC requirements:

UL 1053 allows

- 2 Sec. Max. time delay up to 150% of Pickup setting
- 1 Sec. Max. time delay above 250% of Pickup setting

NEC Section 230

The maximum setting of the ground fault protection shall be 1200A and the maximum time delay is 1 sec. for ground faults equal to or greater than 3000A

Response Curve

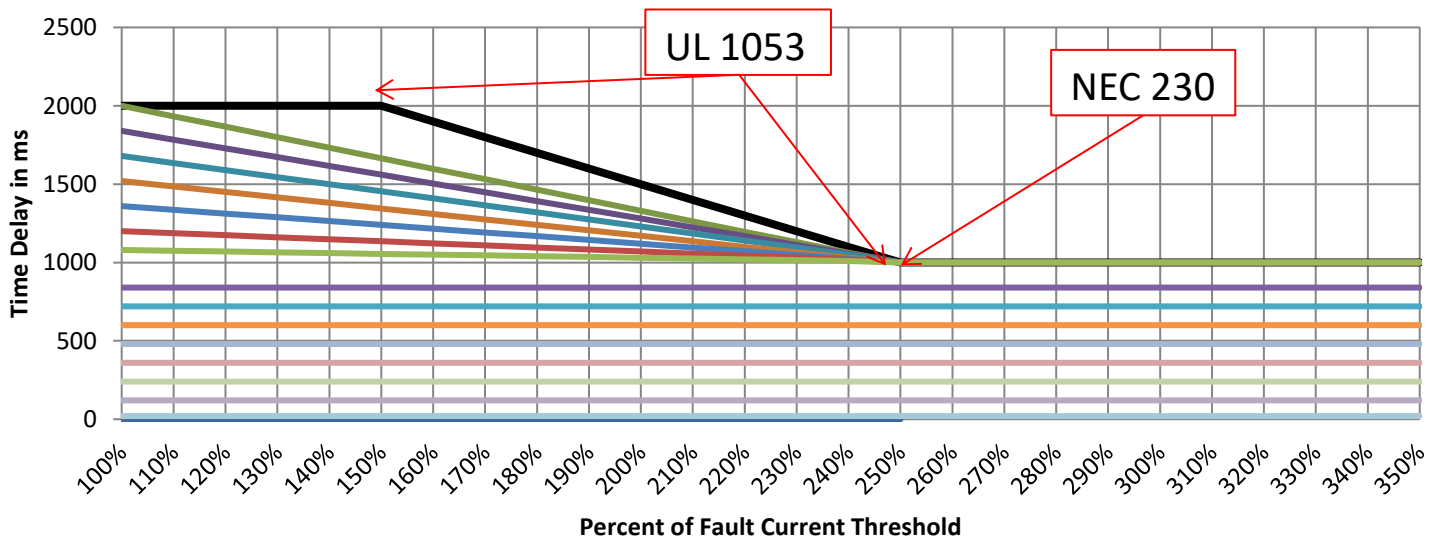



Electromagnetic Industries LLP

www.electromagnetic.biz

Typical Installation Diagram

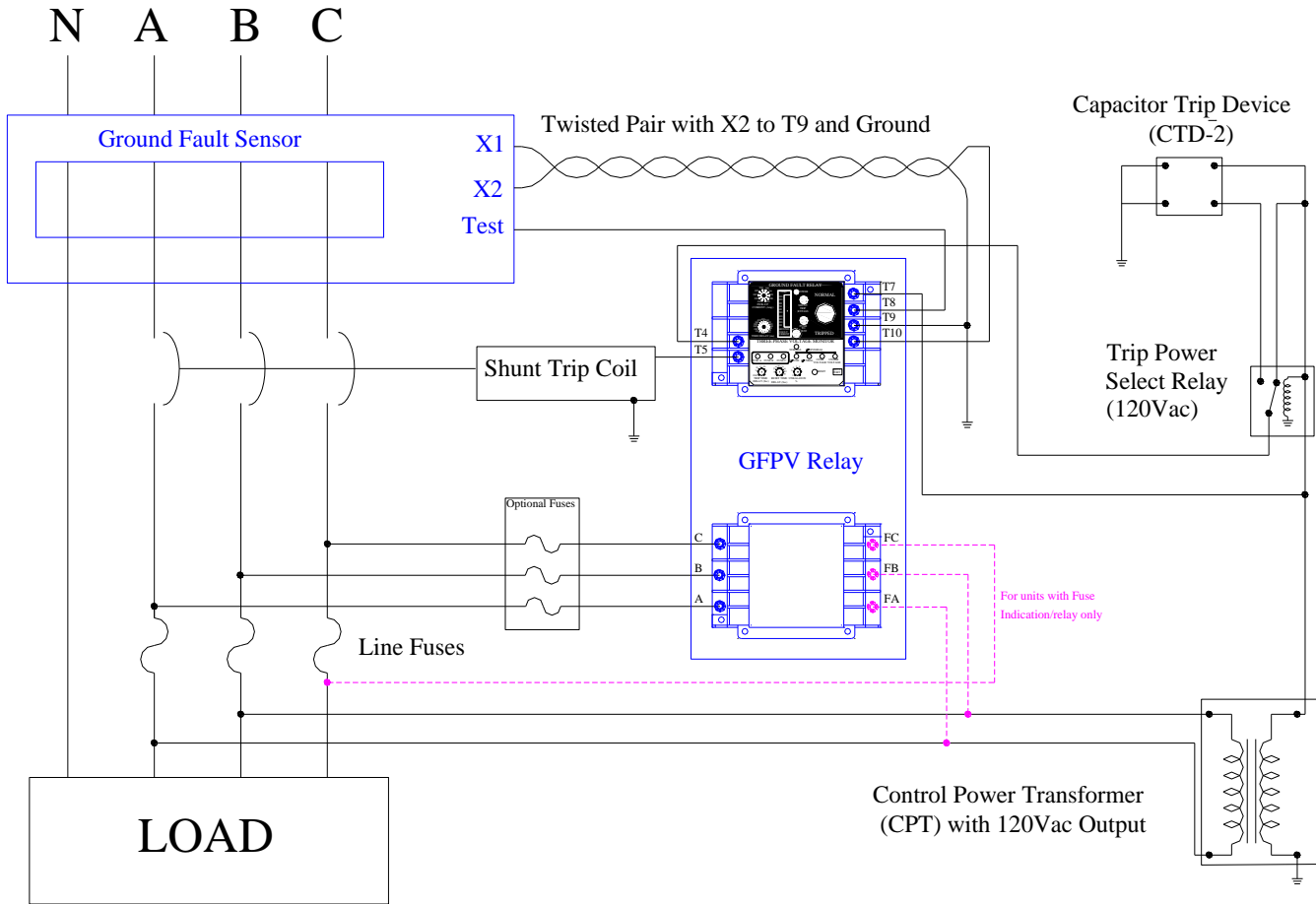

Notes:

- 1) Contacts between terminals T4 and T5 are normally open and close in the "TRIP" condition.
- 2) The Capacitor Trip Device (CTD) is used for emergency power to trip the shunt coil in case of loss of AC power from the CPT.
- 3) 120Vac from CPT is used only for power to Test Circuit, charging optional CTD, and operating Shunt Trip Coil. All relay operating power is from the three phases being monitored and the GFPV will operate as long as any one phase is present.
- 4) The optional "Trip Power Select Relay" is used to select AC power when available and DC power from the CTD when AC power is lost.
- 5) Additional Protective Devices (NO) isolated Contacts may be connected in parallel across terminals T4 and T5.



Electromagnetic Industries LLP

www.electromagnetic.biz

Typical GFP Relay and Sensor Installation

Alternate locations for Ground Fault Sensor (GFL)

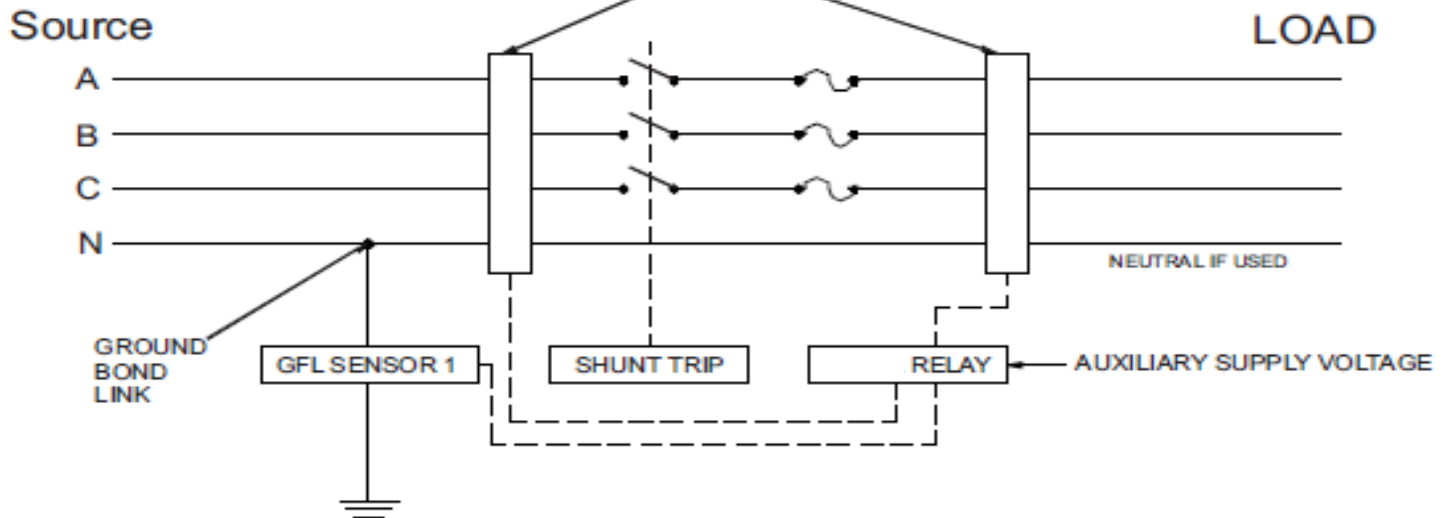

Note: NO GROUNDS PERMITTED DOWNSTREAM OF BOND LINK

CAUTION: This test should be performed by qualified personnel only.

To determine if the neutral is grounded in only one place at the service entrance in accordance with the “National Electrical Code”:

1. De-energize equipment. (Disconnect Power)
2. Remove ground bond link
3. Using a megger, measure resistance of each phase and the neutral to ground. (In accordance with NEC requirements, the resistance should be 1 mega ohm.)
4. Reconnect bond link
5. Reconnect power and check power indication (LED)

To test the entire system (including the disconnect device):

1. Verify control power LED indicator is illuminated.
2. Press the “Push to Test” pushbutton on the GFPV box. (The trip indicator will go to the tripped position and the disconnect device will open)
3. Reset the relay and disconnect device.

To test the GFPV Ground Fault Sensor and Relay only:

1. Verify control power LED indicator is illuminated.
2. Press and hold the “Shunt Trip Bypass” pushbutton on the GFPV box.
3. Press the “Push to Test” pushbutton. (The Ground Fault Relay will trip)
4. Reset the relay, and then release the “Shunt Trip Bypass” pushbutton.

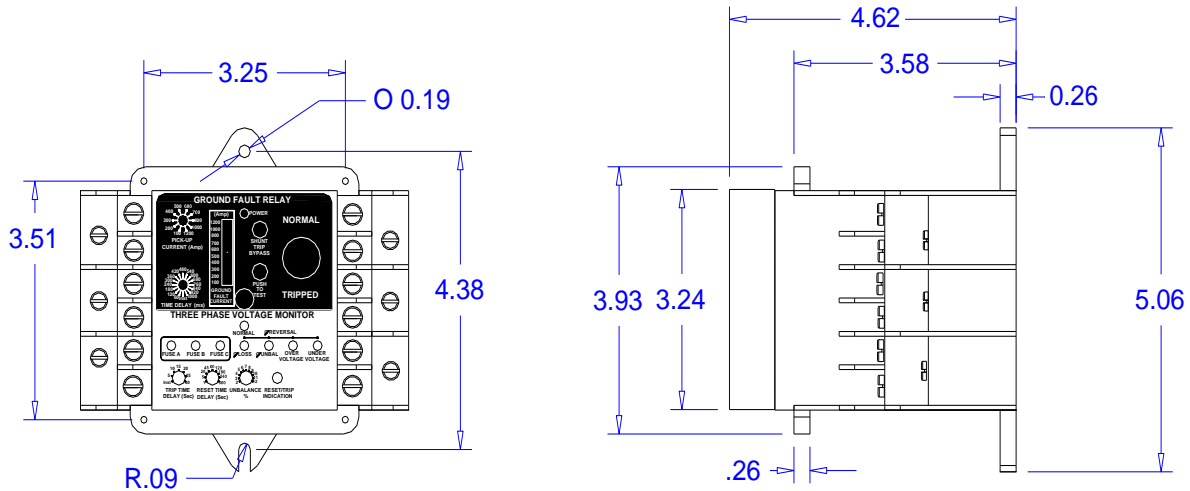

Other Connection Features:

Alarm Contacts

NO
Com
NC

Trip Contacts

NO
Com
NC

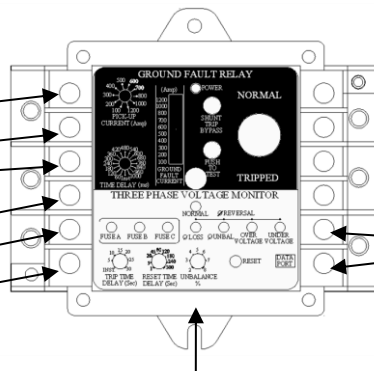

Zone Interlock

12v External Power Supply Connection

Notes:

- 1) The Optional "Alarm Contacts" are dry "Form C" contacts that change state as soon as an abnormal condition is detected, regardless of the Time Delay setting.
- 2) The "Trip Contacts" are dry "Form C" contacts that change state as soon as an abnormal condition is detected and the Time Delay has expired.
- 3) The 12v external power supply is used to allow indication of the last condition after loss of the normal three phase power. This 12v does not affect unit operation, only indication.
- 4) Zone Interlocking can be used with multiple GFPVs and GFP relays, or a combination of the two.
- 5) The Optional port is to connect to the Remote Monitor.



Typical Wiring Diagram for Zone Interlock System

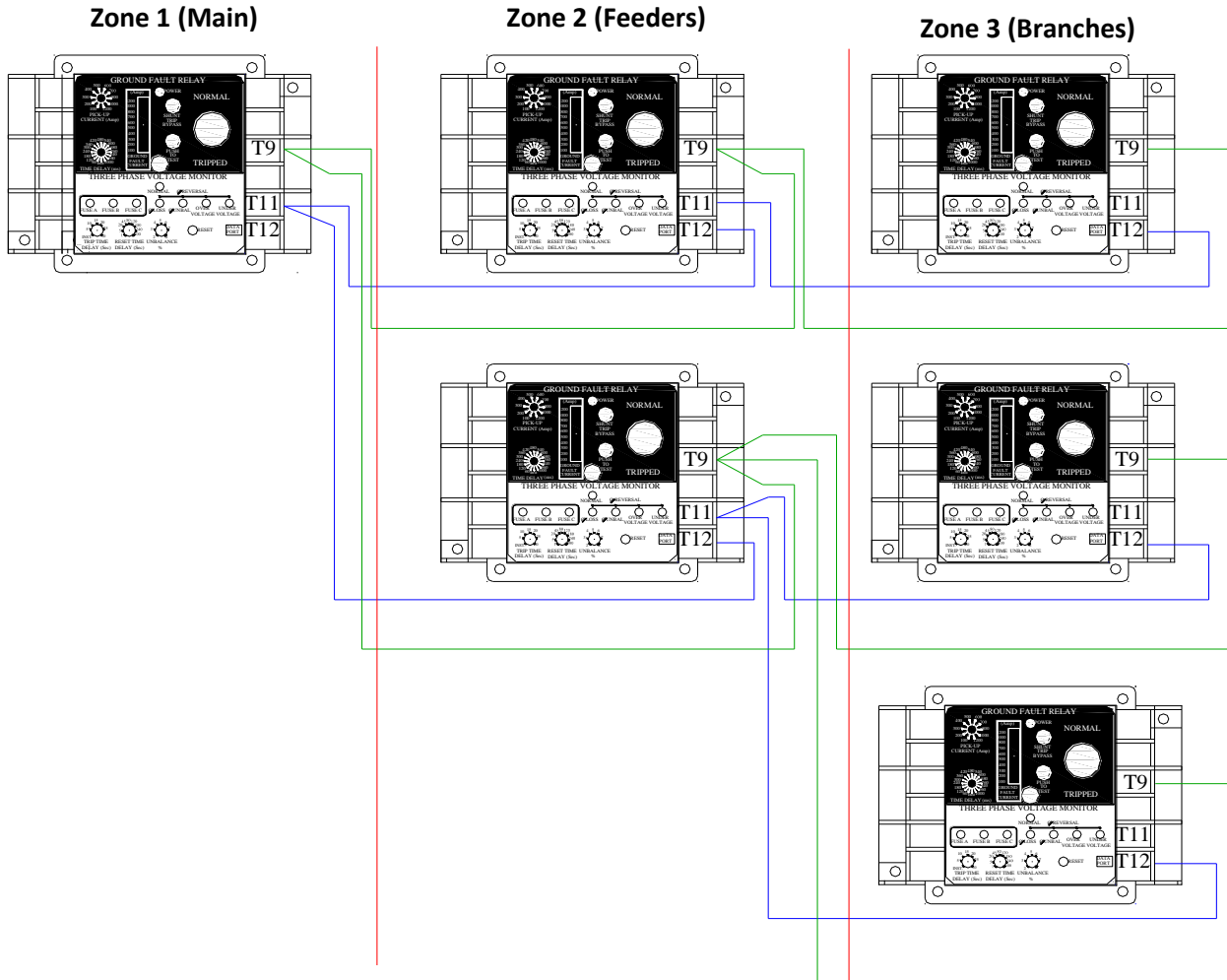

NOTES:

- 1) All Zone Interlock wiring should be twisted pair, 20 AWG or larger.
- 2) Model GFP will communicate with the GFPV. Use the same diagram but replace the T11 w/ TB8 and T12 w/ TB7.
- 3) A limit of 10 upstream units are to be used to a single output.



Optional Remote Monitor:

The optional Remote Monitor allows for system status indication through a communications cable. The remote can be powered from the GFPV and/or by a 12v external power supply.

The Remote Indicator mimics the GFPV indications and will continue to show the condition after power down when the external 12v is provided. The Remote also has a USB connection for Data Log/Data Trend functions.

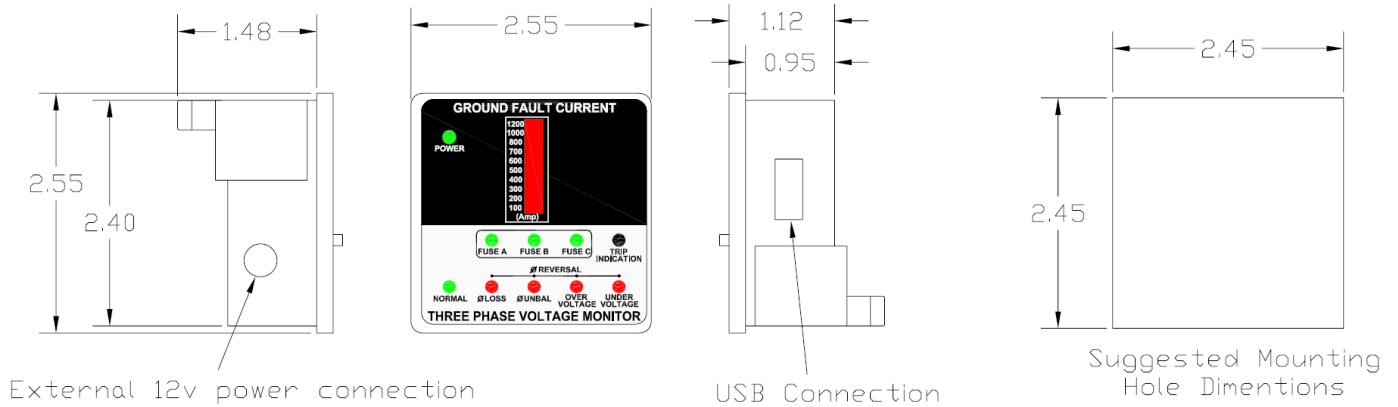

The Data Log/Data Trend function is accomplished by connecting the USB port on the Remote Monitor to a computer equipped with the software provided by Electromagnetic Industries LLP. This software allows for unlimited events to be recorded and gives a pop-up indication on the computer screen any time a condition changes.

Please note, the Remote Monitor Option must be selected on the GFPV Relay in order to use the Remote Monitor and Data Log functions.