



**CURRENT TRANSFORMERS (with Voltage Signal Output)**

**Model CV2 (Window Size: 1.13" Diameters)**

**Application:** Generally used to provide 0 - 1.0Vac output with a current input. (Other secondary voltages also available)

**Frequency:** 50-400 Hz

**Insulation Level:** 600 Volts, 10Kv BIL Full Wave

- Terminals are brass. Stud and Female options w/ hardware available. See Page 2
- Mounting brackets kits for the Model CV2SHT are sold separately. (P/N 1121A00019-1)
- Approximate weight: 0.5 lbs.



**CV2 SFT**



**CV2 SHT**

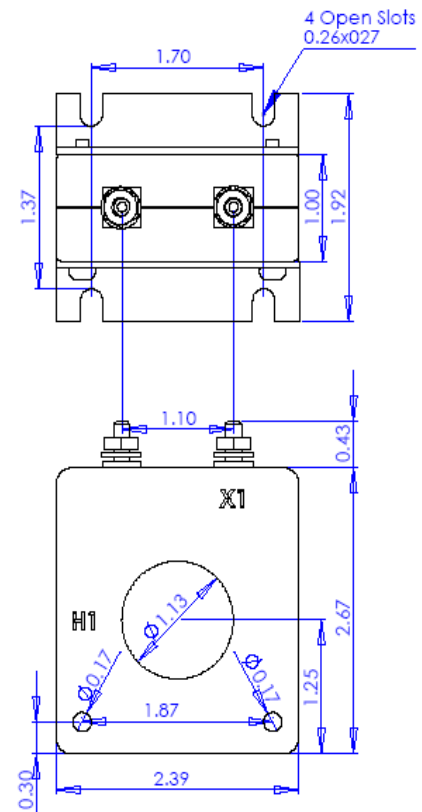
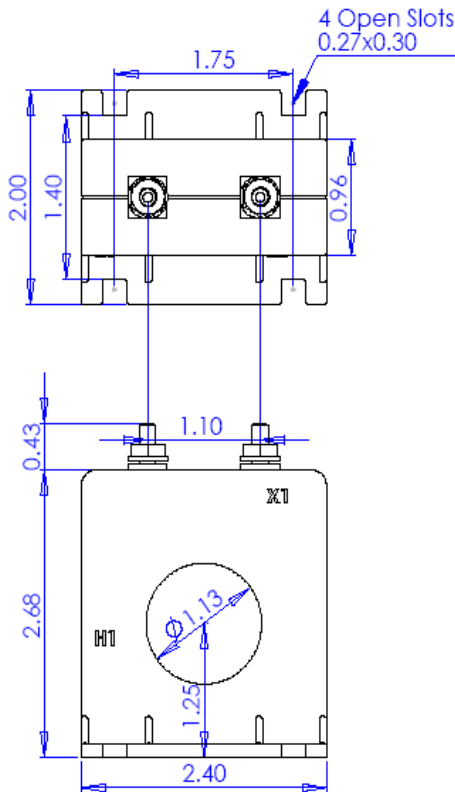



## CURRENT TRANSFORMERS

Model CV2 (Window Size: 1.13" Diameters)

Catalog Number	Primary Current/ Sec. Voltage	Accuracy at 60Hz	TRF @ 30C	TRF @55C
CV2 **-500-1	50A:1V	0.6%	1.0	0.8
CV2 **-600-1	60A:1V	0.6%	1.0	0.8
CV2 **-750-1	75A:1V	0.6%	1.0	0.8
CV2 **-800-1	80A:1V	0.6%	1.0	0.8
CV2 **-101-1	100A:1V	0.3%	1.0	0.8
CV2 **-121-1	120A:1V	0.3%	1.0	0.8
CV2 **-151-1	150A:1V	0.3%	1.0	0.8
CV2 **-201-1	200A:1V	0.3%	1.0	0.8
CV2 **-251-1	250A:1V	0.3%	1.0	0.8
CV2 **-301-1	300A:1V	0.3%	1.0	0.8
CV2 **-401-1	400A:1V	0.3%	1.0	0.8

Note: When ordering, use prefix below to indicate unit designation/configuration. (i.e. CV2SFT-101-1)

SH-\* = Square Case with mounting holes

SF-\* = Square Case w/molded feet and terminals

T = Male (Brass studs No. 8-32 UNC with one flat washer, one lock washer and one nut each)

Y = Female (Brass with one Cup washer, one lock washer and one No. 8-32 UNC binding head screw each)



Y = Female Terminals



T = Male Terminals