



# CAPACITOR TRIP DEVICE

## MODEL CTD-5 (120VAC or 240VAC)

Application: This device provides a source of energy for circuit breaker and switch trip coil operation during a loss of AC control voltage

Operation: The capacitor is continuously charged when control power is available, providing energy for normal trip coil operation. Because mechanical relays are not involved, energy for the trip coil operation is immediately available with the loss of control power. When the control power returns, the capacitor automatically charges to supply energy for the next trip coil operation.

Nominal 120 VAC, or 240 VAC is applied between the "INPUT" terminals. This voltage is half wave rectified and applied across the trip capacitors, yielding an output trip voltage. The charge stored in these capacitors is available between the "+" and "COMMON" terminals for breaker trip coil operation. The half wave rectification circuitry provides the advantage of maintaining a common neutral connection from input to output while still maintaining the charge in the trip capacitor after control power is lost.

An alarm relay is incorporated to continuously monitor the input and output condition of the device. The relay is normally energized when both input and output voltage are present. If either the input voltage is lost or the output voltage falls below 85% of the normal output level the output alarm contacts transfer to their de-energized state. An LED indicates normal operation(remote LED indicator optional). The LED goes out when the alarm contacts transfer to their de-energized state.

These devices are protected against inadvertent output short circuits, inductive kickback from the trip coil, and input line voltage surges.

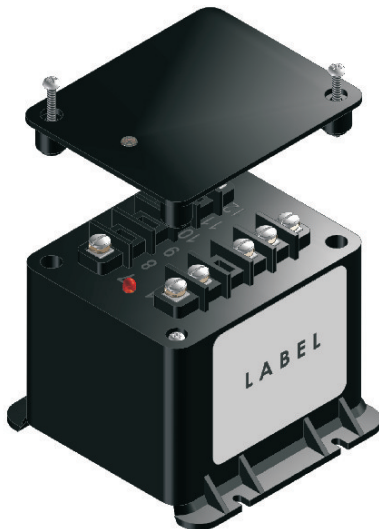

### How to order

Basic Model	Input Voltage	LED Color	Remote LED (Optional)
CTD-5	120 Volt	G = Green	E= Remote LED
	240 Volt	Blank = Red	Blank = LED on case
CTD-5	XXX-	X-	X

SPECIFICATIONS	CTD5-120	CTD 5-240
Normal Input Voltage	120 VAC	240 VAC
Max. Input Voltage	140 VAC	280 VAC
Frequency	DC to 400Hz	DC to 400Hz
Available Energy	64 joules	57 joules
Trip capacitor fully charged at Normal Input Voltage	+/- 20% @ 25 Deg.C	+/- 20% @ 25 Deg.C
Normal Output Voltage	169 Volts DC	338 Volts DC
Approx. Charge Time to 90% AT 25C	1.4 Sec.	570mS
Capacitance	4500uF +/- 20% @ 25 Deg C	990uF +/- 20% @ 25 Deg C
Temp. Influence on Capacitor	10% @ 30 Deg.C/ 5% @ 60 Deg.C	
Ambient Operating Temperature	-30 Deg.C to 60 Deg.C	
Ambient Storage Temperature	-50 Deg. C to 80 Deg. C	
Short Circuit Protection	Continuous	
Mounting	Vertical or Horizontal	
Input Transient Protection	MOV protected to 65 joules single pulse transient	
Output Contact Rating	Resistive: 5A, 250VAC    5A, 30VDC Inductive: 2A, 250VAC    3A, 30VDC 1/6 HP , 120VAC 1/3 HP, 240VAC	

\* FOR RoHS COMPLIANT PART, CONTACT SALES REPRESENTATIVE FOR AVAILABILITY

# CTD-5 DIMENSIONS

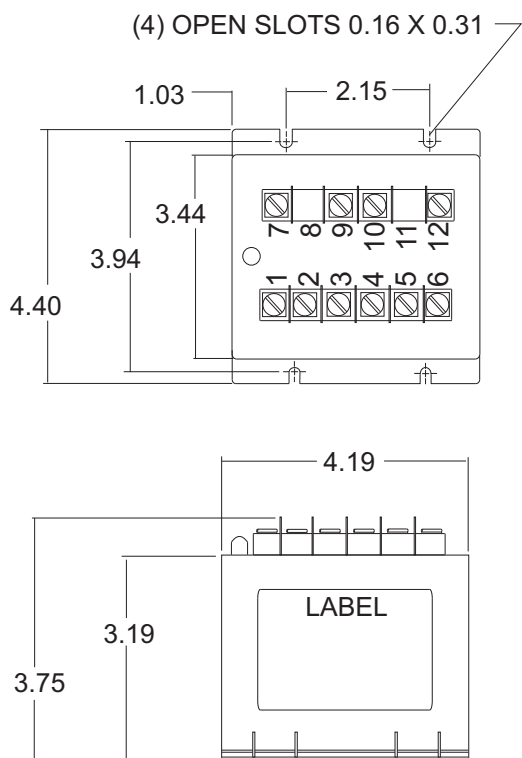

TYPICAL CONNECTION DIAGRAM

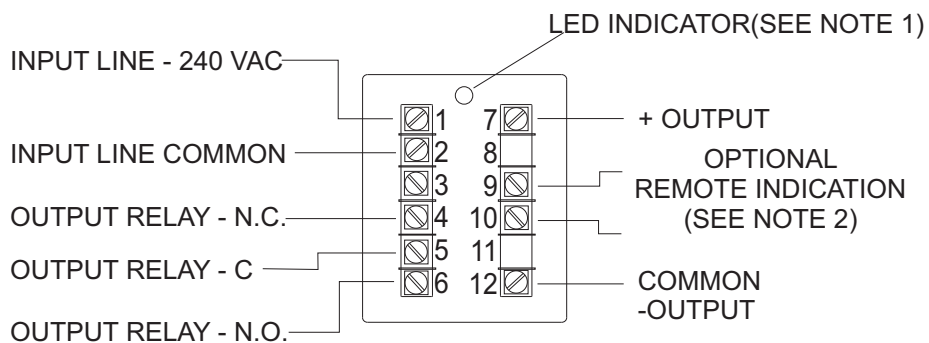

NOTES:

1. The output contacts are shown in the de-energized condition. Contacts will pick up when input and output voltage is present. If the output DC voltage drops below 85% of the expected operating level or the input voltage is lost, the contacts will change state and the LED indicator will no longer be illuminated.
2. Terminals 9 and 10 are for remote LED indication. (To utilize remote indication install remote LED wiring with cathode to terminal 10 and anode to terminal 9)
3. TDR is temperature dependant resistor.

# CTD FUNCTIONAL DIAGRAM

