



CAPACITOR TRIP DEVICE

Models CTD-3

Application: This device provides a source of energy for circuit breakers and switch trip coil operation during a loss of AC control voltage

Nominal Input Voltage: 240 Volts AC
Frequency: 0 - 400Hz.

SPECIFICATIONS CTD-3	
Normal Input Voltage	240VAC
Max. Input Voltage	280VAC
Capacitance	330uF, +/- 20% @ 25 Deg. C.
Available Energy	19 joules, +/- 20% @ 25 Deg. C. (Trip capacitor fully charged at normal input voltage.)
Temp. influence on Capacitor	(-10% at -30 Deg. C., +5% at 60 Deg. C.)
Short Circuit Protection	Continuous
Normal Output Voltage	338 VDC
Normal Charge Time	Approximate charge time to 90% at 60Hz / 25C (350mS)
Operating Temperature	-30 Deg. C. to 60 Deg. C.
Storage Temp Range	-50 Deg. C. to 80 Deg. C.
Mounting	Vertical or Horizontal
Input Surge Protection	Mov Protection to 65 joules single pulse surge transient

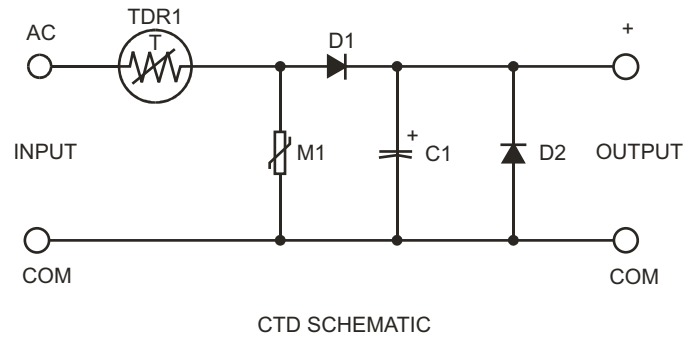
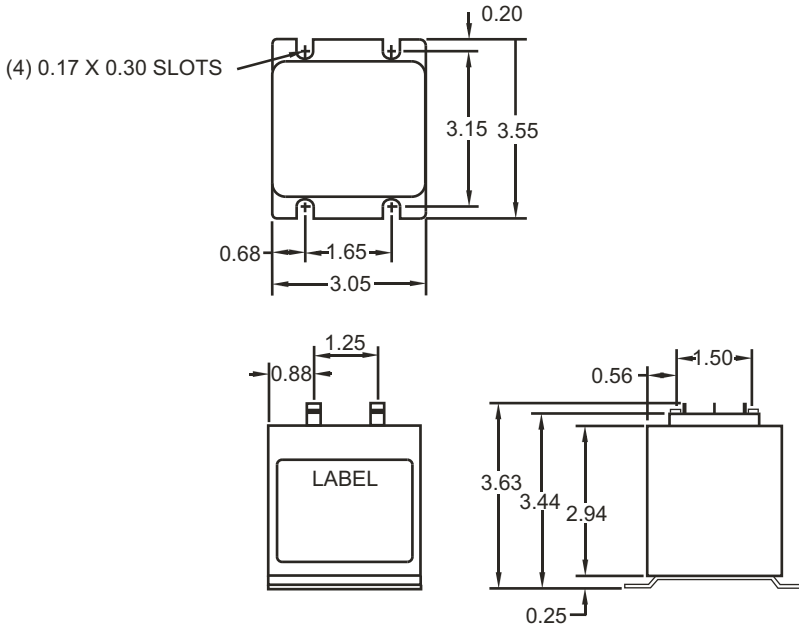
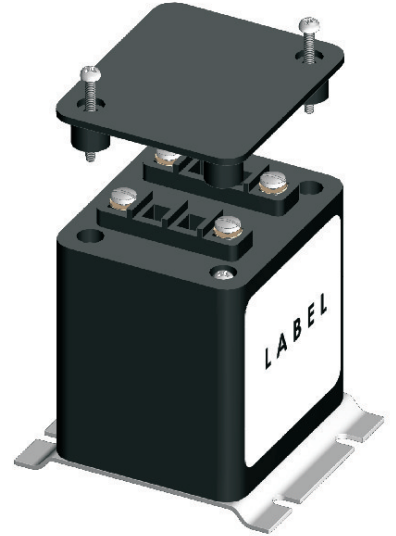

These devices are protected against inadvertent short circuits, input from line surges and inductive kickback from trip coils.

Nominal 240Volts AC is applied between "AC" and "COM" terminals. This voltage is half wave rectified and applied across the trip capacitor to give the output trip voltage. The charge stored in the capacitor is available between "+" and "COM" terminals for the trip coil operation. The half wave rectification circuitry provides the advantage of maintaining a common neutral connection from the input and output while still maintaining the charge in the trip capacitor after a loss of control power.

The capacitor is continuously charged when control power is applied. This provides energy for normal trip coil operation. Because mechanical relays are not used, energy from the trip coil operation is immediately available with the loss of control power. When the control power returns, the capacitor will recharge and will be able to supply energy for the next trip coil operation.

* FOR RoHS COMPLIANT PART, CONTACT SALES REPRESENTATIVE FOR AVAILABILITY